

IGLÙ' H 8 cm



APPLICATIONS

Ventilated under-floor cavities for civil and industrial buildings that are being built new or reconstructed. - Urban infrastructure structures - Creation of an intermediate slab or roofing for cavities used for ventilation and the passage of systems. - Rooms used for humidity and temperature control: drying cells, cold rooms, greenhouses, storage rooms and cellars. - Underground pipes for the passage of utilities. Inspectionable cavities and pits. - By filling it in simply with expanded clay, it can be used to create roof-top gardens. - Underground ducts for the dispersion of water and for drainage. - Overhead sidewalks for passenger loading and unloading or the creation of floating floors. - Levelling height.

Made of ALAPLEN® CS20

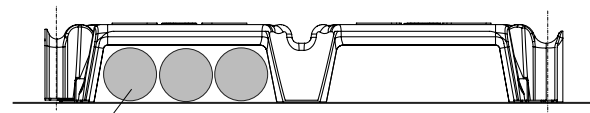
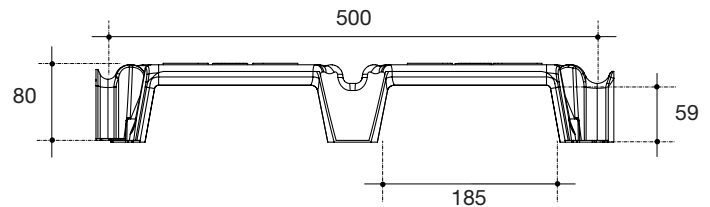
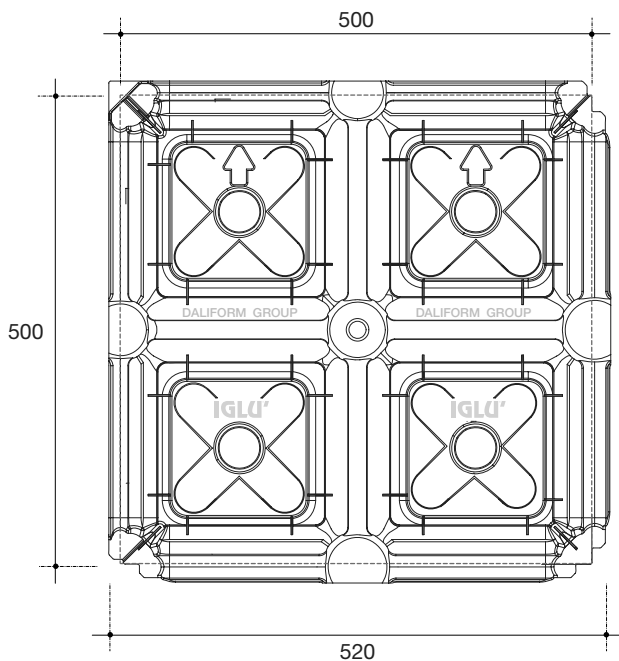

Passage of nr. 3 tubes Ø 56 mm for tunnel

Measures are express in mm.*

* Recyclable material is allowed a size tolerance of $\pm 1,5\%$.



0,010 m³/m²

Quantity of concrete to the crown**

** The volume may vary depending on the pouring condition and the tolerance of the material.

IGLU' H 8 cm

Pressures at the bottom of the structure

Loads kg/m ²	Slab cm	Mesh Ø mm cmxcm	Thickness of the lean concrete cm	Pressure at pillar base kg/cm ²
1.500	3	Ø5 / 25 X 25	0	7,40
			5	1,10
			10	0,47
5.000	4	Ø5 / 20 X 20	6	2,90
			10	1,42
			15	0,76
8.000	8	Ø6 / 20 X 20	10	2,20
			15	1,20
			20	0,74

The table expresses, starting from the various examples of overload and of thickness (to be given to the slab), the pressures that would be applied to the feet of the structure, in relation to the (eventual) thicknesses of the lean concrete.

The overload hypotheses are indicated in table as an example; the actual load capacity is far superior. To know the exact values or sizing as shown in the project, contact the technical department.

To contact the technical office:

Tel. +39 0422 208350 - tecnico@daliform.com

To obtain updated technical cards, support material, new photos and case studies, go to www.daliform.com - The technical consultancy is only valid for the Daliform Group construction systems.

Technical data and packing

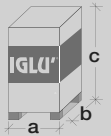
IGLU' H 8 cm			
Pallet dimensions 	Pallet dimensions	cm	110x110x256
	Sq.mt. per pallet	m ² /PAL	150
	Pieces per pallet	pz/PAL	600
	Pallet weight	kg/PAL	640
L-Plast panels	H	cm	205
	L	cm	13
	P	cm	

Accessories

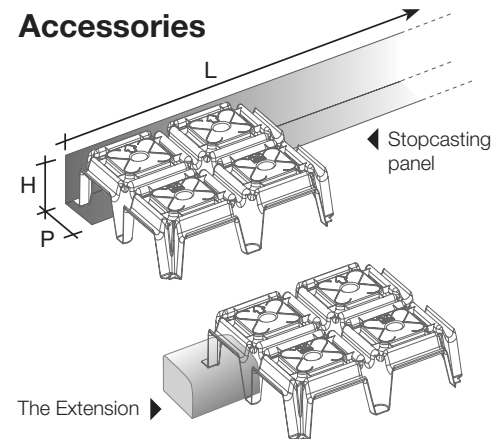

Dry-stone time-exposure of **IGLU'** : 80 m²/h

Dry assembly method

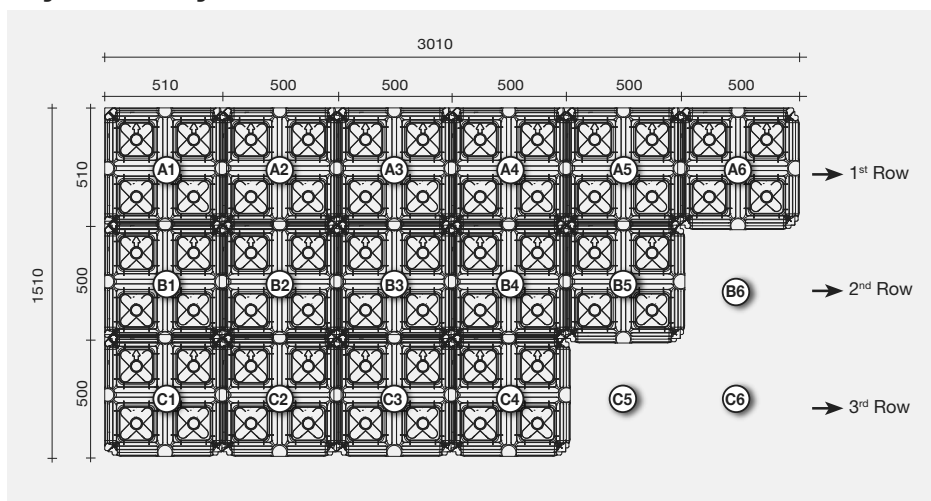

 To ensure a correct installation and perfectly created under-floor cavity please refer to the product's usage requirements.

rev. 12-10/17

The information contained in this catalogue could be changed. Before placing an order, request a confirmation or updated information from the DALIFORM GROUP, which reserves the right to make changes at any moment without notice. In consideration of recycled material, it is specified that there are tolerance margins caused by environmental factors.